

# Nut Insulators

## Use

The Nut Insulator is used to cover the hex bolts and nuts etc. used to join busbars in electrical switchboards, when the bars are covered by insulation material.

## Description

The Nut Insulator will accommodate a typical belleville washer, or flat and spring washer for the bolt size (e.g. M10). It is high enough to allow for a normal amount of protrusion of the bolt or screw through the nut. The cap can be used on the bolt head or nut.

The three 'fingers' inside the cap exert sufficient pressure against the bolt head or nut to keep it in place, but allow removal by hand. This also allows for the small variations in head size.

The easy addition of the shaft ring increases the pressure on the bolt head or nut. This is used when the nut insulator should only be removed by a tool in accordance with the relevant standards. A lever is inserted between one of the external ribs and the bar. The ribs also indicate the position of the 'flats' on the bolt head to facilitate positioning.

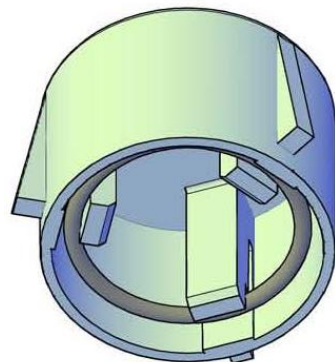
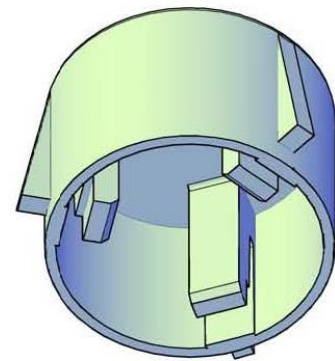

# Material

The nut insulators are injection moulded from type 6 nylon, flame retarded.

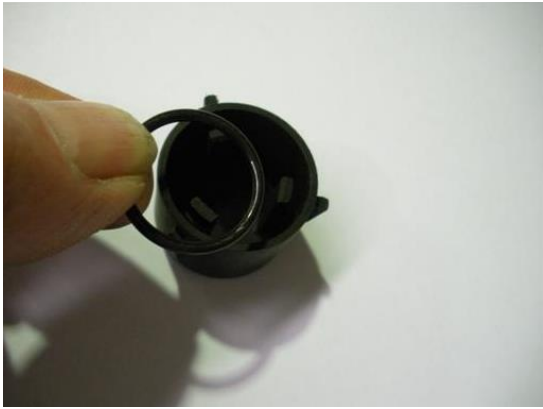

Ring being fitted to the Nut Insulator



Nut Insulator (with ring)  
being prised off with the aid of a screwdriver

*This product is protected by:  
Australian Innovative Patent no 2011101356  
Registered Design Applied for*

---

## KENTAN ENGINEERING

A.B.N. 21 009 217 654

Units 1-4, 8 Carole Road (Main Office Unit 3)  
MADDINGTON, Western Australia 6109

PO Box 284  
MADDINGTON, Western Australia 6989

International Telephone: +61 8 9493 5255

National Telephone: (08) 9493 5255

Email: [sales@kentan.com.au](mailto:sales@kentan.com.au)

Internet: [www.kentan.com.au](http://www.kentan.com.au)



KENTAN ENGINEERING IS A QUALITY ASSURED COMPANY